



Doosan Infracore
Construction Equipment

MEGA 160 MEGA 160 TC

Engine power: 72 kW / 97 Hp
Operational weight: 8.600 ~ 8.900 kg
Bucket capacity (SAE): 1,5 ~ 1,6 m³

MEGA 200-V MEGA 200-V LONG BOOM MEGA 200-V TC

Engine power: 116 kW / 156 Hp
Operational weight: 11.200 ~ 11.500 kg
Bucket capacity (SAE): 1,8 ~ 2 m³



Technical specifications

Mega 160, Mega 160 TC = [1] — Mega 200-v, Mega 200-v Long Boom, Mega 200-v TC = [2]

* Engine

• General Description

[1]: DB58 S [2]: DB58 TIS
 6 cylinders, direct injection.
 Mega 160: naturally aspirated.
 Mega 200-v: turbo charged, aftercooled.
 3 steps air filtration: pre-cleaner,
 main element and safety element.
 (Turbo II precleaner for Mega 200-v)
 Sucker fan driven by a hydraulic motor.

• Engine characteristics

MAX NET (SAE J1349, ISO 9249)
 [1]: 72 kW (97 Hp) at 2.200 rpm.
 [2]: 116 kW (156 Hp) at 2.000 rpm.
 RATED GROSS (SAE J1995)
 [1]: 74 kW (99 Hp) at 2.200 rpm.
 [2]: 107 kW (143 Hp) at 2.200 rpm.
 RATED NET (SAE J1349, ISO 9249)
 [1]: 72 kW (97 Hp) at 2.200 rpm.
 [2]: 105 kW (141 Hp) at 2.200 rpm.

• Max Net Torque (SAE J1349, ISO 9249)

[1]: 363 Nm at 1.600 rpm.
 [2]: 608 Nm at 1.600 rpm.

• Max torque

157 kgf.m (1.540 Nm) at 1.300 rpm

• Displacement

5,8 l

• Bore x Stroke

102 mm x 118 mm

• Battery voltage

24 V

• Capacity of the 2 maintenance free batteries

[1]-[2]: 150 (Ah)

• Starter power

4,5 kW

• Alternator output

50 A

* Hydraulic system

Gear pumps.

[1]: double [2]: triple

Sealed system and automatic wear compensation.
 All hydraulic lines are equipped with special seals (ORFS).

• Max. flow

[1]: 140 l/m [2]: 175 l/m

• Relief Pressure

[1]-[2]: 200 bars

• Lifting & tilting cylinders

Bore x stroke (mm) [number of cylinders]

	Mega 160	Mega 160 TC
Lifting	110 x 680 [2]	105 x 673 [2]
Tilting	130 x 400 [1]	80 x 635 [2]

	Mega 200-v	200-v Long Boom	200-v TC
Lifting	120 x 717 [2]	120 x 743 [2]	105 x 673 [2]
Tilting	140 x 490 [1]	140 x 490 [1]	80 x 815 [2]

• Loading cycles time (sec)

	Mega 160		Mega 200-v	
	Z	TC	Z	TC
Lifting speed	6	6	5	5,2
Dumping speed	1,5	2,4	1,2	1,4
Lowering speed	3,1	3	3,3	3,3
Total	10,6	11,4	9,5	9,9

* Lifting system

Z system

The lifting system with one tilt cylinder and Z configuration is designed for the toughest jobs allowing high breakout forces and fast movements.

TC system

The lifting system with two tilt cylinders is designed for allrounder activities.

With two tilt cylinders, high breakout force can be reached. The bucket angles are kept constant when the arm is lifted. No bucket correction is needed.

* Cab

The modular cab allows excellent visibility in all directions. Numerous ventilation outlets obtain the optimal ventilation. Touch buttons control the air re-circulation air conditioning and heating systems.

The air of the cab is filtered.

All necessary information for the operator is centralised in front of him.

The majority of the main functions are actuated via switches located on a console at the right of the operator.

Generous storage places are well located.

The cab is mounted on viscous elements to offer a better comfort for the operator.

• Access door

1

• Emergency exits

2

The cab conforms ROPS ISO 3471 and FOPS ISO 3449

• Guaranteed external noise level Lwa

following 2000/14/EC

[1] : 105 dB(A) [2] : 108 dB(A)

* Axles

Rigid front axle, oscillating rear axle with outboard planetary reductions.

• Oscillation angle

11°

• Max. vertical movement of the rear wheel

[1] : ± 362 mm [2] : ± 376 mm

• Brake

Wet multi-disc.

Independent circuit for each axle.

Dual pedal braking system

Parking brake.

Oil released, spring applied, hydraulic releases (on front axle).

Hydraulic control by switch.

Complies with: ISO 3450/EEC 71/320; SAE J1473

* Steering system

The steering system is a load sensitive type.

• Steering angle:

[1]-[2] : 40°

• Oil flow (l/min)

[1] : 140* [2] : 85

* uses main hydraulic flow

Relief pressure (bars)

[1] : 170 [2] : 175

Steering cylinders (2)

Bore x stroke (mm)

[1] : 60 x 395 [2] : 70 x 370

The emergency steering pump is actuated automatically by an electric motor.

* Transmission

The "Full Power Shift" transmission can be used in manual or automatic modes.

This transmission is based on components having excellent worldwide reputations. It is equipped with a modulation system allowing soft gear shifting and inversion of travel direction. Safety devices also protect the transmission from incorrect operations.

The gear and direction shifting is operated by a single lever to the left of the steering wheel. A travel direction control is also mounted on the hydraulic joystick.

With a special electronic device, the transmission can be tested and adjusted easily for optimum performance and efficiently.

The transmission can be de-clutched by the operation of brake pedal to increase the power available to the hydraulic pumps.

A safety device prevents the starting of the engine when not in neutral.

• Torque converter

Single stage, one phase.

Max Torque ratio:

[1] : 3,057:1 [2] : 2,910:1

• Gear box

Maker and models:

[1] : ZF4 WG 130

[2] : ZF4 WG 160

• Tyres

[1] : 17.5 – 25 VKT (L2)

[2] : 20.5 – 25 VKT (L2)

• Speed Forward / Rearward (km/h)

1: [1] : 6,6/7,1 [2] : 8,2/8,5

2: [1] : 11,7/12,2 [2] : 14,3/15

3: [1] : 21,4/22,4 [2] : 25/26,3

4: [1] : 34,5/- [2] : 39/-

• Max. traction force (Tons)

[1] : 8

[2] : 10,9

* Maintenance

Maintenance is easy due to excellent access.

The transmission is electronically controlled.

An error coding system allows easy diagnosis of the systems and proper intervention.

• Capacities (l)

Engine: [1] : 13 [2] : 21

Radiator: [1] : 29 [2] : 31

Fuel: [1] : 185 [2] : 260

Hydraulic oil: [1] : 100 [2] : 150

Gear box and torque converter: [1] : 20 [2] : 30

Front axle: [1] : 18 [2] : 20

Rear axle: [1] : 18 [2] : 20

Operational data

			Mega 160	Mega 160	Mega 200-V	Mega 200-V	Mega 200-V
			Z	Parallel (TC)	Z	Z (Long Boom)	Parallel (TC)
			General purpose	General purpose	General purpose	General purpose	General purpose
Bucket type			General purpose	General purpose	General purpose	General purpose	General purpose
Configuration			Straight	Straight	Straight	Straight	Straight
Bucket code (equipped with teeth)			M160-GP15-D-T	M160-GP15-Q-T	M200-GP19-D-T	M200-GP18-D-T	M200-GP19-Q-T
Bucket code (equipped with extra blade)			M160-GP16-D-B	M160-GP16-D-B	M200-GP20-D-B	M200-GP19-D-B	M200-GP20-Q-B
				With coupler			With coupler
Capacity heaped ISO/SAE (with teeth)		m ³	1,5	1,5	1,9	1,8	1,9
Capacity heaped ISO/SAE (with blade)		m ³	1,6	1,6	2	1,9	2
Bucket width	A	mm	2.450	2.450	2.550	2.470	2.500
Breakout force		kN	77	44	103	103	90,7
Static tipping load (straight position)		kg	6.500	5.400	8.500	7.393	8.150
Static tipping load (articulated position 40°)		kg	5.300	4.500	7.400	6.432	7.080
Dump height (at 45°/ teeth)*	J	mm	2.685	2.429	2.730	2.909	2.473
Dump reach (at 45°/ teeth)*	I	mm	1.073	1.164	960	1.227	1.090
Dump height (at 45°/ blade)*	J'	mm	2.745	2.516	2.765	3.040	2.576
Dump reach (at 45°/ blade)*	I'	mm	1.020	1.068	929	1.147	1.023
Digging depth	H	mm	73	67	50	94	158
Height at bucket pivot point	K	mm	3.610	3.690	3.830	3.979	3.738
Max angle at carry position	α	°	50	40	45	43	34
Max angle at fully raised	β	°	47	46	66	56	44
External radius at tire side	R	mm	4.858	4.858	5.230	5.230	5.230
External radius at bucket edge	D	mm	5.390	5.566	5.659	5.965	5.945
Wheel basis	G	mm	2.700	2.700	2.900	2.900	2.900
Width at tyres	B	mm	2.310	2.310	2.453	2.453	2.453
Tread	V	mm	1.870	1.870	1.930	1.930	1.930
Tyres			17,5-25 VKT	17,5-25 VKT	20,5-25VKT	20,5-25VKT	20,5-25VKT
Ground clearance	C	mm	450	450	450	450	450
Overall length	F	mm	6.540	6.857	7.035	7.545	7.253
Overall height	E	mm	3.180	3.180	3.260	3.260	3.260
Operating weight		kg	8.660	9.030	11.200	11.310	11.700

* Variations according bucket equipment (teeth or with extra blade)

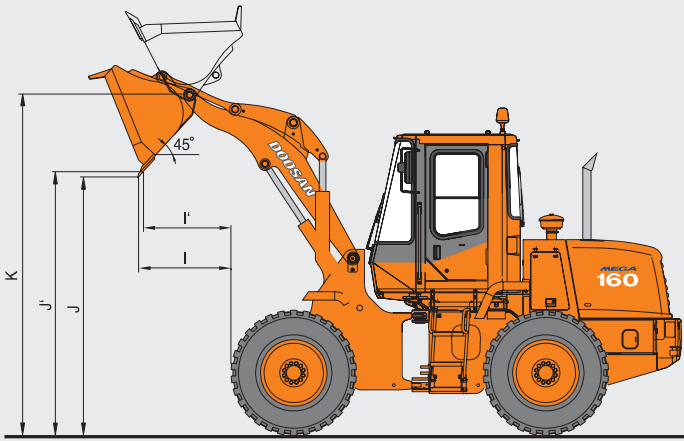

Z cinematic

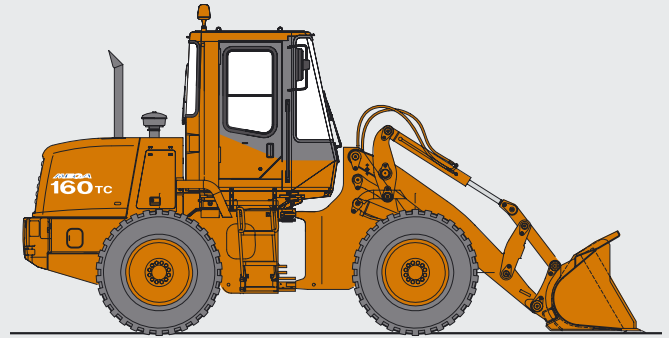

Parallel cinematic (Tool Carrier)

Dimensions

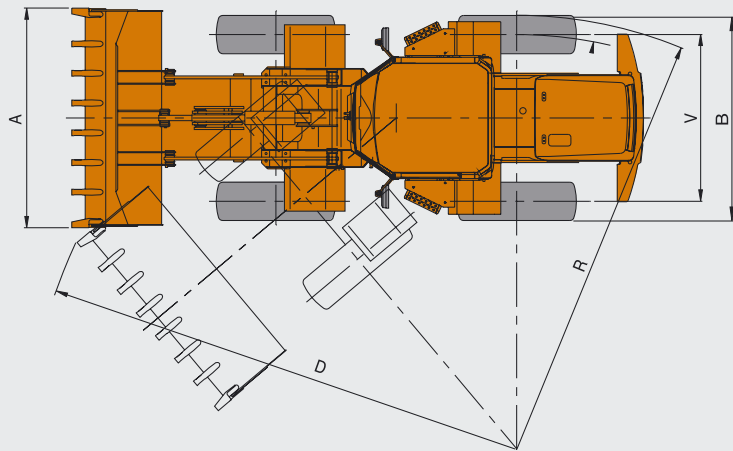
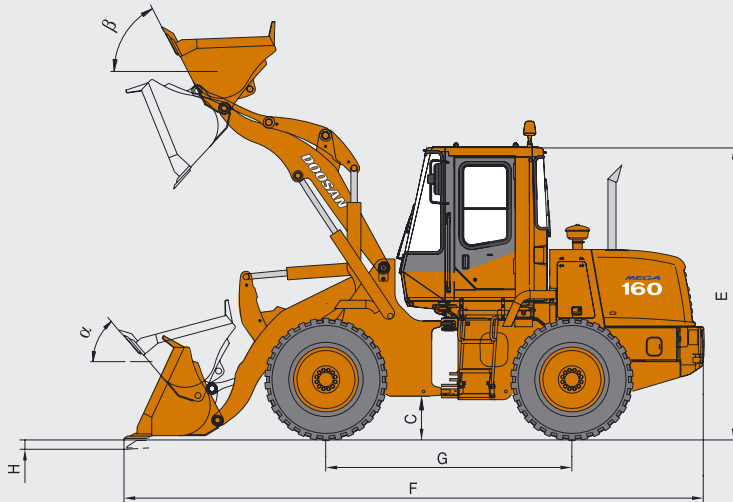

Equipped with pallet fork

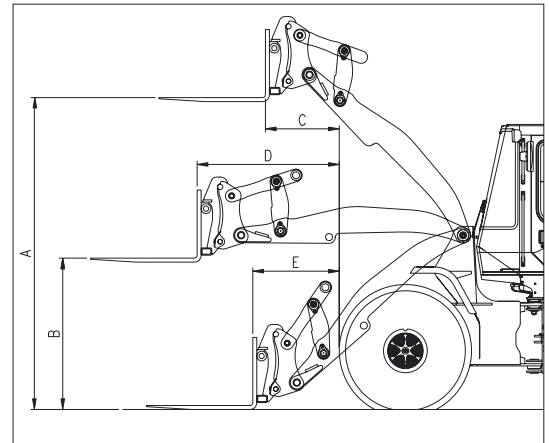

			Mega 160 TC	Mega 200-VTC
Max. stacking height	A	mm	3.450	3.506
Height of forks at maximum reach	B	mm	1.624	1.702
Reach at maximum height	C	mm	881	831
Reach at arms horizontal	D	mm	1.681	1.600
Reach at ground level	E	mm	1.116	974
Weight in working order with fork tins		kg	8.910	11.300
Max. tipping load, straight ISO 8313		kg	4.314	5.796
Max. tipping load, articulated position		kg	3.775	5.072
Max. payload on flat and hard soil as per EN 474-3 at 80% of tipping load in articulated position		kg	3.020	4.057
Max. payload on uneven soil as per EN 474-3, 60% of tipping load in articulated position		kg	2.265	3.043

Reliability

Every morning, when the operators commence work, they know that things will go smoothly - because DOOSAN has taken care of it. The product is solid. The entire structure of the machine is built to guarantee a long and reliable life. The components of the drive train are proven and reliable. Operators know that they have significant reserves at hand and that they won't have to push the machine to its limit. The DOOSAN wheeled loaders are designed and built to last.

For DOOSAN, 'reliability' means availability, accessibility and simplicity.

We believe that technology must serve man – not that man serves technology. And although our machines (like all machines) are designed and set up by engineers, it's important for us that it's easy for everyone to use and service them. Excellent relationships, with a spirit of working in partnership, are the foundation of our dealer network. We encourage them to have a close proximity to our customers. You can trust our dealers. You can always rely on them to find a solution. They can, for example, provide any replacement part from their own stock, or from our central spare parts facility in Belgium – the same site where other machines such as our hydraulic excavators are manufactured.



Spare parts, readily available.

Axles generously dimensioned. Outboard planetary hub reductions to limit the torsional stresses in the driveshafts.



The hoses and cylinders that are exposed are especially well protected.



ORFS Connections (hydraulic piping sealing joints) ensure good tightness security.

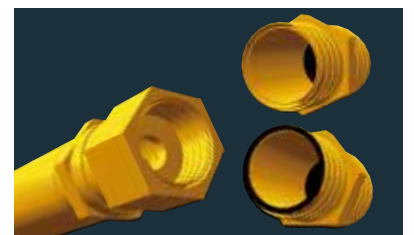

Noise measurement and program for noise reduction in anechoic chamber.



Simulation of extreme weather conditions (cold, warm and wet weather).



Rolling conditions simulations (braking, acceleration, drawbar pull, heat dissipation ...).

Standard and optional equipment

* Standard equipment

• Engine

- Three stage air cleaner with restriction indicator on the dashboard
- Turbo II pre-filter for Mega 200-v
- External drains for engine oil and cooling liquid changes

• Electricity

- Working lights: 2 at the front and 2 at the rear
- Driving lights: low and high beams
- Tail, indicators, stop, reversing lights
- Reversing alarm

• External equipment's

- Lifting hooks
- Articulation lock in the transport position
- Towing hitch
- Wheel chocks
- Tools compartment

• Lifting and Hydraulic system

- Robust Z bar lifting system
- Bucket capacities (SAE)
 - Mega 160 : 1,6 m³
 - Mega 160 TC : 1,5 m³
 - Mega 200-v (standard) : 1,9 m³
 - Mega 200-v (long boom) : 1,8 m³
 - Mega 200-v TC : 1,8 m³
- Single lever joystick with auxiliary lever for third function. (Mega 160 and Mega 160 TC)
- Single lever joystick with auxiliary lever for third function + FNR. (Mega 200-v and Mega 200-v TC)
- Hydraulic control valve with three sections
- Boom adjustable lift Kick out
- Bucket kick out
- Hydraulic lock of bucket and arm cylinders
- Load insulation system (LIS) (Mega 200-v and Mega 200-v TC)
- Fast couplers for hydraulic check

* Optional equipment

Some of this optional equipment may be standard in some markets. Some of the optional equipment cannot be available on some markets. You must check with the local DOOSAN dealer to know about the availability or to release the adaptation following the needs of the application.

• Working tools

- Quick coupler
- Various types of buckets
- Pallet fork
- Crane jib

• Tyres

- L3, L4, L5 from various manufacturers
- Mega 200-v / 200-v TC : 17.5-25
- Wide basis tyres (65)
 - Mega 160 / 160 TC : 550/65 R25
 - Mega 200-v / 200-v TC : 600/65 R25
 - 650/65 R25

• Hydraulic

- Floating position function

• Steering system

- Load sensing steering system
- Emergency steering system electrically actuated

• Cab

- Air-conditioning / heating with re-circulation function
- Air cab Filtration
- Adjustable steering column
- Compartment for can's
- Floor mat
- Tinted glasses
- Flat floor
- Left and right sliding windows
- Front and rear wiper
- Front and rear washers
- Sun visor
- Interior cab light
- Interior rear view mirror
- Exterior rear view mirrors (2)
- Machine monitoring (condition, control & maintenance indicators in front of the driver by dials, gauges and lamps)
- Main switches in front of the driver
- Switches for the general functions in the right console
- Electrical horn
- Cigarette lighter
- Pre equipment for radio

• Drive line

- Gear box which can be de-clutched when braking
- Gear box with diagnosis and monitoring indicator, and electronic plug for a fast adjustment.
- Selection of Manual or Automatic mode
- Starting safety system
- Kick-down and travelling direction selection: lever at left of the steering wheel or on the joystick
- Dual braking circuit with pump and accumulator

• Electricity

- Rotating beacon
- Additional lighting

• Cab

- Special filtration for polluted environment
- Rear Camera (CCTV) and monitor
- Radio AM/FM

• Various

- Full covering mudguard
- Central greasing
- Start system for cold areas
- Weighing system
- Catalytic muffler
- Anti spark arrestor
- Tool Kit

DOOSAN Infracore Europe S.A.

1st, rue Achille Degrâce
7080 Frameries, Belgium
Tel : +32-65-61 32 30 • Fax : +32-65-67 73 38

DOOSAN Infracore France SA

Buroplus 2
Parc d'Activités de La Clef St Pierre
Avenue Jean d'Alembert, bâtiment n° 2
78990 Elancourt, France
Tel : +33-1-30 16 21 41 • Fax : +33-1-30 16 21 44

DOOSAN Infracore U.K., Ltd.

Doosan House, Unit 6, 3 Heol-Y-Gamlas, Parc Nantgarw,
Nantgarw, Cardiff CF15 7QU, U.K.
Tel : +44-1443-84-2273 • Fax : +44-1443-84-1933

DOOSAN Infracore Germany GmbH

Heinrich-von-Stephan-Str. 2
D-40764, Langenfeld, Germany
Tel : +49-2173-2035212 • Fax : +49-2173-2035219

Head Office

Doosan Tower 26th FL. 18-12, Euljiro-6Ga,
Jung-Gu, Seoul, Korea 100-730
Tel : +82-2-3389-8114 • Fax : +82-2-3389-8117

www.doosaninfracore.com

www.doosaneurope.com

