

CROWN

RT 3000 Series
rider pallet truck

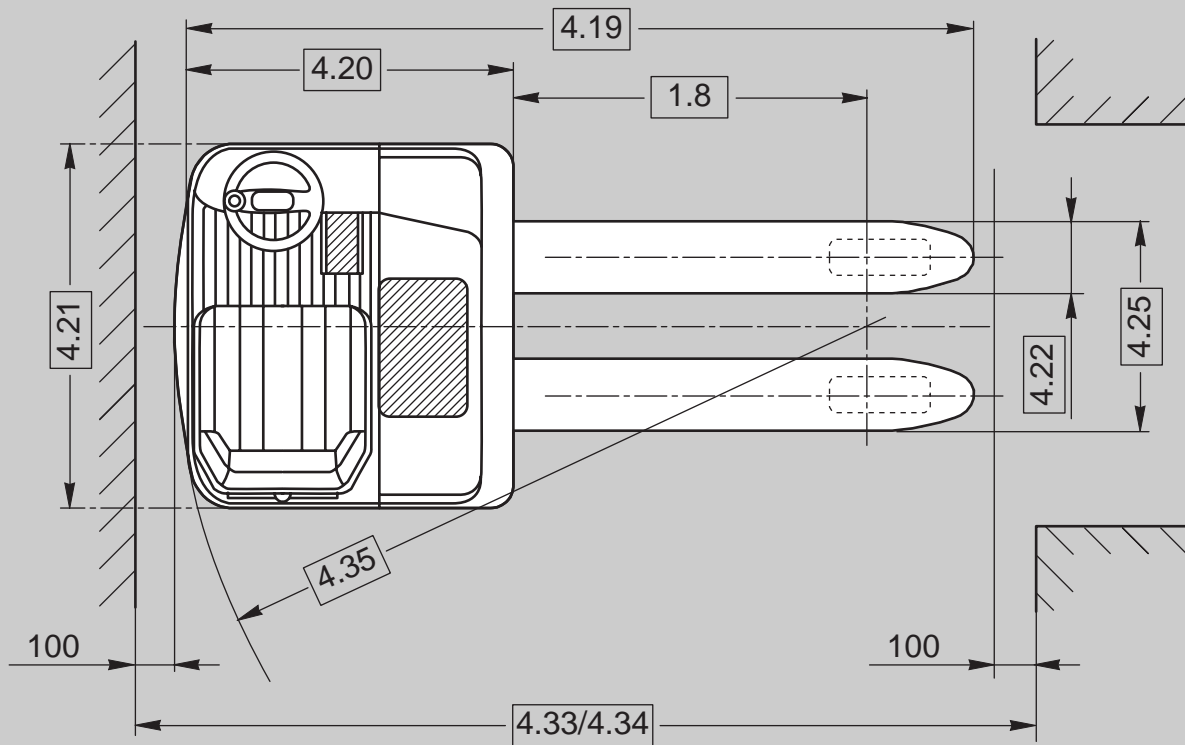

specifications

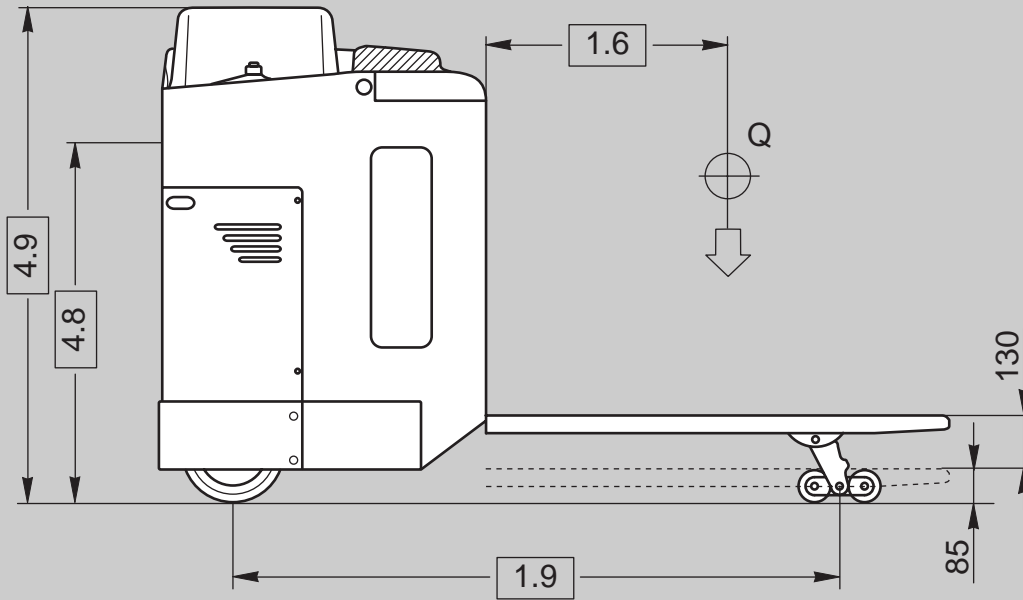

Specifications Series RT 3000

		Crown Equipment Corporation						
General Information	1.1	Manufacturer						
	1.2	Model			RT 3010	RT 3020	RT 3030	
	1.3	Prime Mover	electric					
	1.4	Operator Type			stand	sit down	sit down	
	1.5	Load Capacity [▲]		Q	t	2	2.2	3.3
	1.6	Load Centre		c	mm	600		600/1200
	1.8	Load Distance	forks lowered	x	mm	748/928		965/1618
			forks raised	x	mm	702/882		873/1526
	1.9	Wheel Base	forks lowered	y	mm	1414/1594	1386/1563	1792/2444
forks raised			y	mm	1368/1548	1340/1517	1700/2352	
Weights	2.1	Weight		kg	650	600	810/970	
	2.2	Axle Load		kg	1154/1846	1173/2028	1700/3070-1757/3173	
	2.3	Axle Load		kg	700/210	764/237	1080/300-1210/330	
Tyres	3.1	Tyre Type	D/C/L					
	3.2	Wheel Size		mm	Ø 260x85		Ø 343x114	
	3.3	Wheel Size		mm	Ø 85x70			
	3.4	Additional Wheels	castor wheel		mm	Ø 150x50		Ø 200x75
	3.5	Wheels	number (x = driven) front/rear			1x, 2/4		
	3.6	Track Width	front	b10	mm	452	573	543
	3.7	Track Width	rear	b11	mm	358	358	380
Dimensions	4.4	Lift		h3	mm	130		
	4.8	Seat Height		h7	mm	-	925	990
	4.9	Truck height		h14	mm	1295	1330	1400
	4.15	Lowered Fork Height		h13	mm	85		
	4.19	Overall Length	at fork length 1150 mm	l1	mm	2000	1965	2190
	4.20	Headlength		l2	mm	850	815	1040
	4.21	Overall Width	front	b1	mm	770	900	950
	4.22	Fork Dimensions		thxwxl	mm	45x172x960/1150		70x180x1150/2350
	4.25	Width Across Forks		b5	mm	530		
	4.31	Ground Clearance		m1	mm	35		
4.33	Working Aisle Width	1000 x 1200 travers lowered	Ast	mm	2075/2075	2055/2050	2280/3670*	
4.34	Working Aisle Width	800 x 1200 length lowered	Ast	mm	2275/2275	2255/2250	2480/3670*	
4.35	Turning Radius	lowered	Wa	mm	1625/1801	1603/1779	2044/2686	
Performance	5.1	Travel Speed			km/h	8.5 / 10		8 / 11
	5.2	Lift Speed			m/s	0.02 / 0.07		
	5.3	Lowering Speed			m/s	0.11 / 0.05		
	5.7	Gradeability			%	8 / 17		7 / 17
	5.10	Service Brake				electric		hydraulic
Motors	6.1	Traction Motor	60 min. rating		KW	1.5		5
	6.2	Lift Motor	15 % on time		KW	2		
	6.2a	Steer Motor	option / option / standard		KW	0,2 option		
	6.3	Max. Battery Box Size		lxwxh		275x725x580	210x810x580	411x827x627
				lxwxh		-	215/315x855x620**	519x827x627
	6.4	Battery Voltage	nominal capacity 5h rating		V/ Ah	24/270L	24/270L; 440L**	48/330L; 440L***
6.5	Battery Weight	nominal ± 5%		kg	260/270	270/405	570	
Misc.	8.1	Type of Controller	traction / steer			transistor / opt.transistor		transistor
	8.2	Available Work. Pressure			bar	140	160	150
	8.4	Noise Level			dB(A)	< 70		

* Load length 2400 mm

** Special "L" shaped battery box, battery changing only possible with overhead crane

*** Increases L2 (4.20) by 110 mm

▲ Capacities on forks lengths up to 1150 mm.

Contact CROWN for capacities on extended fork lengths.

Standard Equipment**RT 3010**

1. 24V electrical system.
2. SEM Traction Motor Technology.
3. On-board diagnostics with service interval counters.
4. Spring-applied, electro-magnetic released brake. Load sensing 2-stage brake system.
5. Self levelling load rollers.
6. Pivoting twin castor wheels.
7. Mosfet Transistor control.
8. Battery discharge indicator with speed reduction, integrated hourmeter and service code display.
9. Electrically height adjustable backrest.
10. Forks 960; 1150 mm.
11. Manual steering with no kickback
12. Horizontal removal of battery to one side.
13. Vulkollan® tyres.

RT 3020

1. 24V electrical system.
2. SEM Traction Motor Technology.
3. On-board diagnostics with service interval counters.
4. Spring-applied, electro-magnetic released brake. Load sensing 2-stage brake system.
5. Self levelling load rollers.
6. Pivoting twin castor wheels.
7. Mosfet Transistor control.
8. Battery discharge indicator with speed reduction, integrated hourmeter and service code display.
9. Spring loaded seat with 4 adjustments.
10. Multifunction control handle to select travel direction, raise, lower and horn.
11. Manual steering with no kickback.
12. Battery can be removed horizontally to one side or lifted out from above. On special „L“ shaped battery box, battery changing only possible by lifting.
13. Vulkollan® tyres.

RT 3030

1. 48V electrical system.
2. SEM Traction Motor Technology.
3. On-board diagnostics with service interval counters.
4. Electric power steering.
5. Regenerative braking system.
6. Pivoting twin castor wheels.
7. Mosfet Transistor control.
8. Battery discharge indicator with speed reduction, integrated hourmeter and service code display.
9. Spring loaded seat with 4 adjustments.
10. Multifunction control handle to select travel direction, raise, lower and horn.
11. Electric power steering with tilting steer wheel.
12. Battery can be removed horizontally to one side or lifted out from above.
13. Vulkollan® tyres.

Optional Equipment**RT 3010 / 3020 / 3030**

1. Electric power steering for RT 3010 and 3020.
2. Fork lengths up to 3600 mm.
3. Width across forks 650 mm.
4. Battery compartment rollers.
5. Battery extractor trolley.
6. Pallet entry/exit rollers.

Safety Regulations

Conforms to European safety standards.

Dimensions and performance data given may vary due to manufacturing tolerances. Performance is based on an average size vehicle and is affected by weight, condition of truck, how it is equipped and the conditions of the operating area. Crown products and specifications are subject to change without notice.

Electrical System

Microprozessor controlled traction controller with on-board service diagnostics and storage register for fault history. High efficiency traction motor due to high frequency switching of MOSFET controller, increases battery shift life. Maximum stepless acceleration at a controlled rate. The seperately excited motor technology eliminates forward and reverse contactors and provides high torque. Regenerative motor braking saves energy and dramatically reduces brush wear and extends motor life by reducing motor temperatur.

Reduced traction speed when steering is turned greater than 10°, ensures safe operation.

Drive Unit

Heavy-duty gear box with helical spur input gear for low noise. Seperate excited drive motor is mounted vertically in a well ventilated motor compartment, ensures optimum accessibility, reduced heat and contamination.

Steering

Steering effort applied by the operator is transmitted through an adjustable twin chain drive to a universal shaft on RT 3010 and 3020 models, with a clutch preventing kick back on the steering wheel.

RT3030 trucks are equipped with electrical steering system and a seperate MOSFET steering controller with on-board service diagnostics and storage register for fault history.

Fork / Lift Mechanism

Fork levelling linkage between the tandem load wheels automatically level the forks and the load when operating on uneven floors on RT3010 and RT3020.

European Manufacturing:

Crown Gabelstapler GmbH & Co. KG
Roding, Germany

Crown Equipment
Galway, Ireland

