

CROWN

Specifications

Series WR

Heavy Duty Walkie
Reach Stackers

Series

WR



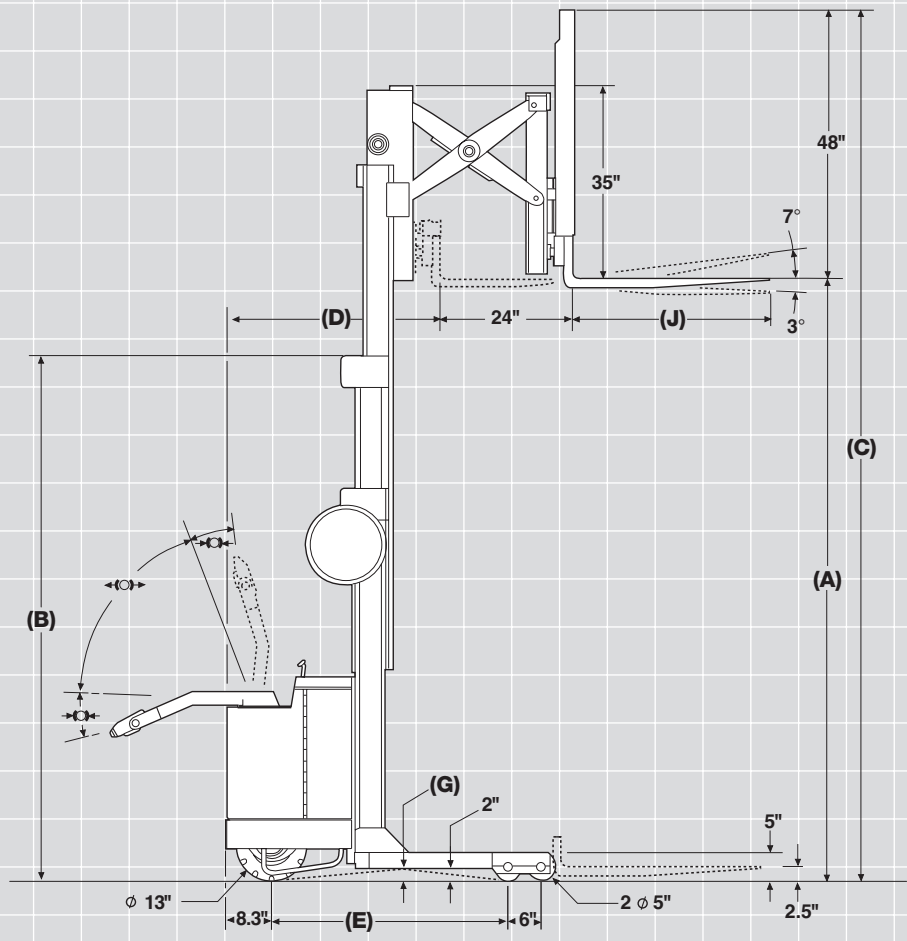
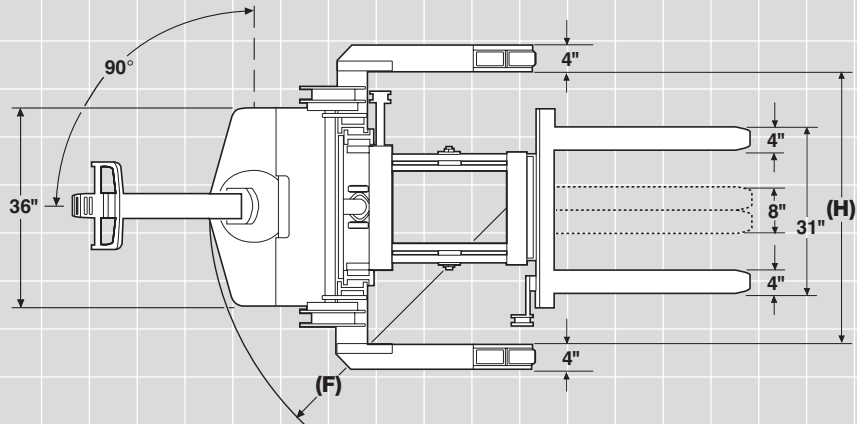

Series WR

Specifications

Model 20 WR 2000 lb rated capacity at 24" load center		20WRTL Limited Free Lift			20WRTF Full Free Lift			20WRTT Triple Stage
A	Lifting Height	102"	126"	150"	102"	126"	150"	152"
	Free Lift	12	12	12	23*	35*	47*	23*
B	Collapsed Height	71	83	95	71	83	95	71
C	Extended Height*	150.5	174.5	198.5	150.5	174.5	198.5	200.5
	Net Weight Less Battery lb	2965	3075	3255	3035	3145	3325	3615
D	Head Length†	38.8	38.8	38.8	38.8	38.8	38.8	42
E	Wheelbase†	43	43	43	43	43	43	46.2
F	Turning Radius†	54.2	54.2	54.2	54.2	54.2	54.2	57.6
G	Grade Clearance				14%			
	Battery Option 1				12%			
	Battery Option 2				12%			
	Maximum Battery Size	6.62" x 35.06" x 23.25" High						
	Battery Option 1	13.12" x 31.75" x 23.25" High						
	Battery Option 2	13.12" x 31.75" x 23.25" High						
H	Inside Straddle	34" to 50" in 2" increments						
	Outside Straddle (Overall Width)	8" plus inside straddle dimension						
J	Fork Lengths	30", 36", 42" & 48" (1.5" thick x 4" wide)						
	Overall Length (Forks Retracted)	Head Length (D) + Fork Length (J)†						
	Minimum Battery Weight	510 lb						

Model 30 WR 3000 lb rated capacity at 24" load center		30WRTL Limited Free Lift			30WRTF Full Free Lift			30WRTT Triple Stage
A	Lifting Height	102"	126"	150"	102"	126"	150"	152"
	Free Lift	12	12	12	23*	35*	47*	23*
B	Collapsed Height	71	83	95	71	83	95	71
C	Extended Height*	150.5	174.5	198.5	150.5	174.5	198.5	200.5
	Net Weight Less Battery lb	2965	3075	3255	3035	3145	3325	3615
D	Head Length	45.2	45.2	45.2	45.2	45.2	45.2	48.5
E	Wheelbase	49.5	49.5	49.5	49.5	49.5	49.5	52.8
F	Turning Radius	60.8	60.8	60.8	60.8	60.8	60.8	64
G	Grade Clearance	12%						
	Maximum Battery Size	13.12" x 31.75" x 23.25" High						
H	Inside Straddle	34" to 50" in 2" increments						
	Outside Straddle (Overall Width)	8" plus inside straddle dimension						
J	Fork Lengths	30", 36", 42" & 48" (1.5" thick x 4" wide)						
	Overall Length (Forks Retracted)	Head Length (D) + Fork Length (J)						
	Minimum Battery Weight	975 lb						

* Add 13" to free lift of WRTF and WRTT models, and subtract 13" from extended height of all models if load backrest is not required.

† Add 6.5" if Option 2 battery compartment is used.

Series WR

Aisle Planning Guide

A - Equal Intersecting Aisles
B - Right Angle Aisles

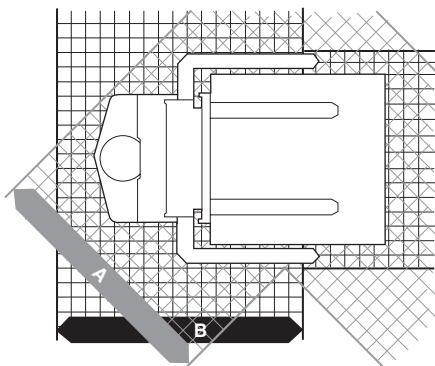

Option 1 Battery Compartment

		20WRTL and 20WRTF*							
Load Length		30"	36"	42"	48"				
Load Width		A	B	A	B	A	B	A	B
30"		58	75	58	75	58	81	59	87
36"		60	77	60	77	60	83	61	89
42"		63	79	63	79	63	85	64	91
48"		66	81	66	81	66	87	67	93

		20WRTT*							
Load Length		30"	36"	42"	48"				
Load Width		A	B	A	B	A	B	A	B
30"		59	78	59	78	59	84	59	90
36"		61	80	61	80	61	86	62	92
42"		64	82	64	82	64	88	65	94
48"		67	84	67	84	67	90	68	96

Option 2 Battery Compartment

		20 and 30WRTT							
Load Length		30"	36"	42"	48"				
Load Width		A	B	A	B	A	B	A	B
30"		62	83	62	83	62	89	63	95
36"		64	85	64	85	64	91	65	97
42"		67	87	67	87	67	93	68	99
48"		71	89	71	89	71	95	71	101

		20 and 30WRTL and WRTF							
Load Length		30"	36"	42"	48"				
Load Width		A	B	A	B	A	B	A	B
30"		61	81	61	81	61	87	62	93
36"		63	82	63	82	63	88	64	94
42"		67	84	67	84	67	90	67	96
48"		70	86	70	86	70	92	70	98

Note: Add 6" to aisle widths "A" and "B" for maximum maneuverability.

*30WR models are not available with Option 1 Battery Compartment.

Capacities

Model 20WR: 2000 lb at 24" load center. (48,000 in./lbs)

Model 30WR: 3000 lb at 24" load center. (72,000 in./lbs)

Maximum Battery Size

Option1: 6.62" wide x 35.06" long x 23.25" high. (20WR Only)
Option 2: 13.12" wide x 31.75" long x 23.25" high.

Batteries

Option1: Up to 255 amp hours, 24 volts.
Option 2: Up to 600 amp hours, 24 volts.

Larger compartment is standard on 30WR models and a minimum battery weight of 975 lbs. is required.

Travel Speeds

In third speed: Loaded, 2.7 mph. Empty, 3.2 mph.

Lifting/Lowering Speeds (fpm)

Loaded (L), Empty (E)

Models	Lifting Speed		Lowering Speed		L	E		
	20WR		30WR					
	L	E	L	E				
WRTF	26	55	26	42	26	28	29	28
WRTL	35	55	28	42	34	28	28	28
WRTT	30	55	29	42	32	28	34	28

Wheels and Tires

Polyurethane Drive Tire - 13" dia. x 4.5" wide x 8" dia. hub pressed-on high profile with smooth tread.

Tandem Load Wheels - 2.75" wide, 5" dia. polyurethane. Load wheels have sealed bearings. Axles are flush to prevent skid and pallet damage.

Forks

1.5" thick x 4" wide. Forged steel forks with full upset heel standard on all models. Overall fork width is adjustable from 8" to 31". Fork lengths - 30", 36", 42" and 48". Fork Carriage on all models is standard ITA Class II hook-type.

Hydraulic System

Standard equipment includes:

1. Heavy duty motor and gear pump assembled as an integral unit. Pump and motor unit hinged for easy accessibility to electrical system.
2. Spool-type hydraulic control valve with built-in check and relief valve.
3. Pressure compensating flow control valve at base of lift cylinder regulates maximum lowering speed.
4. Lift cylinder rams are hard chrome plated for smooth operation and increased life and are equipped with long-lift polyurethane packings. Lift cylinders are designed to operate at optimum hydraulic pressure depending on capacity of truck. All WRTF and WRTT models are equipped with three cylinder cluster to provide full free lift.
5. Movable oil reservoir permits easy accessibility to hydraulic system.
6. Overload valve set to prevent lift when system reaches maximum pressure.
7. Centrally located levers for raising, lowering, tilt, and reach are standard equipment. These throttles permit infinite control of fork positioning.

Electrical System

Standard equipment includes:

1. 24 volt electrical system.
2. Series wound high torque .85 h.p. drive motor.
3. Series wound high torque 5 h.p. lift motor.
4. Heavy duty pump contactor with replaceable tips.
5. Four heavy duty travel speed contactors. A solid-state time relay provides controlled acceleration between 2nd and 3rd speed.
6. Fused control and power circuits.
7. Color coded wiring for ease of service.
8. Key switch.
9. Power disconnect lever.

Reach Mechanism

Heavily constructed pantograph type reach mechanism extends 24". Dual reach cylinders used on WRTL and WRTF units. Large single cylinder used on all triple telescopic units. Mechanism features: chrome plated cylinder rods, hydraulic cushions at both ends of stroke, lifetime-lubricated sealed channel roller bearings, anti-friction bearings at center pivots, and self-aligning, grease lubricated spherical bearings.

Tilt

Carriage tilts 7° up and 3° down. (Designed to operate in all reach positions and at all lifting heights.)

Drive Unit

Gear drive from motor to drive wheel axle. The gear train is mounted on ball and tapered roller bearings, and operates in an oil filled, sealed housing.

Brake

Internal expanding mechanical brake with 5" drum and bonded brake linings. Brake is applied when control handle is within 15° of full vertical or full horizontal position.

Power Unit Structure

Hinged access doors permit easy entry to all electric and hydraulic components. Chassis is equipped with rollers for easy battery installation and removal.

Control Handle

Control handle has dual twist-grips which control three speeds forward and reverse. Twist-grips return to neutral when released. The handle contains a large safety button which reverses the direction of the truck should the button touch the operator. A large horn button is standard equipment, as is a third speed cutoff switch.

Safety Switches

1. Third speed switch in control handle may be used to shut off high speed when operating in congested areas.
2. Limit switch automatically reduces maximum travel speed immediately upon extension of second and third stages on WRTF and WRTT models, and when forks extend above 68" on WRTL models.
3. Reversing button on control handle reverses direction of travel when actuated by the operator.

Optional Equipment

1. Transistor speed control.
2. Raise and lower buttons in control handle.
3. Rubber drive tire - 13.5" dia. x 5.5" wide.
4. Safety yellow or orange paint.
5. Discharge indicator.
6. Hour meter.

Other Options

1. Audible Travel Alarm.
 2. Flashing Lights.
- Safety considerations and dangers associated with audible travel alarms and flashing lights include:
- Multiple alarms and/or lights can cause confusion.
 - Workers ignore the alarms and/or lights after day-in and day-out exposure.
 - Operator may transfer the responsibility for "looking out" to the pedestrians.
 - Annoys operators and pedestrians.

Dimensions and performance data given may vary due to manufacturing tolerances. Performance is based on an average size vehicle and is affected by weight, condition of truck, how it is equipped and the conditions of the operating area. Crown products and specifications are subject to change without notice.



Crown Equipment Corporation
New Bremen, Ohio 45869 USA
Tel 419-629-2311
Fax 419-629-3796
crown.com

The Momentum symbols are a trademark of Crown Equipment Corporation.

Because Crown is continually improving its products, specifications are subject to change without notice. Copyright 2002 Crown Equipment Corporation Printed in U.S.A.